

698 SERIES PANEL INDICATOR LED

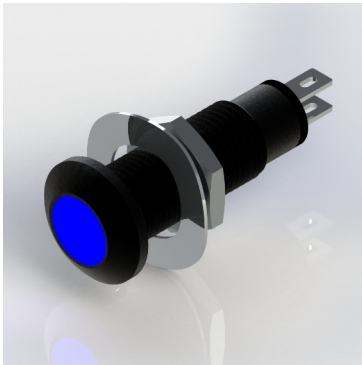

FEATURES

- Ø8.1mm mounting
- Black anodised aluminium housing
- Sealed to IP67 - weatherproof
- Wide viewing angle - smoked lens
- Internal potting
- Bi-polar circuitry
- Range of LED colour options
- Range of voltage options

BENEFITS

- 'D' mounting hole aids anti-rotation
- Suitable for portable equipment
- Suitable for external applications
- Smoked lens gives good on/off contrast ratio
- Suitable for high vibration applications
- Suitable for AC or low voltage DC in any orientation
- Suitable for status panel indication
- Manufactured with internal resistor
- Outstanding reliability
- Vandal resistant

MARL Part Number	LED Colour	Typical Voltage Vopr	Typical Current DC Iopr	Typical LED Luminous Intensity	Typical LED Wavelength λp	Operating Temp Topr *	Storage Temp Tstg
698-501-63	Red	12-28 Vac/dc	6-16	236 @ 10mA	625	-40 to +75	-40 to +100
698-521-63	Yellow	12-28 Vac/dc	6-16	217 @ 10mA	590	-40 to +75	-40 to +100
698-532-63	Green	12-28 Vac/dc	6-16	1360 @ 10mA	520	-40 to +75	-40 to +100
698-930-63	Blue	12-28 Vac/dc	6-16	270 @ 10mA	470	-40 to +75	-40 to +100
698-997-63	Cool White	12-28 Vac/dc	6-16	743 @ 10mA	See Below	-40 to +75	-40 to +100
698-501-75	Red	110 Vac	7	112	625	-40 to +75	-40 to +100
698-521-75	Yellow	110 Vac	7	103	590	-40 to +75	-40 to +100
698-532-75	Green	110 Vac	7	814	520	-40 to +75	-40 to +100
698-930-75	Blue	110 Vac	7	154	470	-40 to +75	-40 to +100
698-997-75	Cool White	110 Vac	7	393	See Below	-40 to +75	-40 to +100
		Bi-polar	mA	mcd	nm	°C	°C

Typical Emission Colours Cool White LED			
X	0.275	0.28	0.29
Y	0.27	0.28	0.30

NOTES

Intensities (Iv) and colour shades of white (X-Y co-ordinates) may vary between LEDs within a batch. Additional LED Colours, Voltage Options and Flying Lead lengths available for semi-custom projects. Please contact our Sales Team. All LED components are supplied in anti-static packaging.

* Characteristics at Ta = 25°C. For operating temperature derating graphs, please refer to sheet 2.

To order please contact us on +44 (0) 1229 582 430
 F +44 (0) 1229 585 155 | E sales@marl.co.uk | www.leds.co.uk
 in company/marl-international-limited



698 SERIES PANEL INDICATOR LED



TECHNICAL CHARACTERISTICS

Series	Max. Power Dissipation	Panel Cutout	Nut Mounting Torque	Min. Mounting Centres	Min - Max. Panel Thickness
698	825	8.1	0.65	14.5	1.5 - 13.0
	mW	mm	Nm	mm	mm

TECHNICAL DRAWING

Weight (g): 4.8

Dimensions in mm (typical). Not to scale. Mounting hole to be clean and burr free.

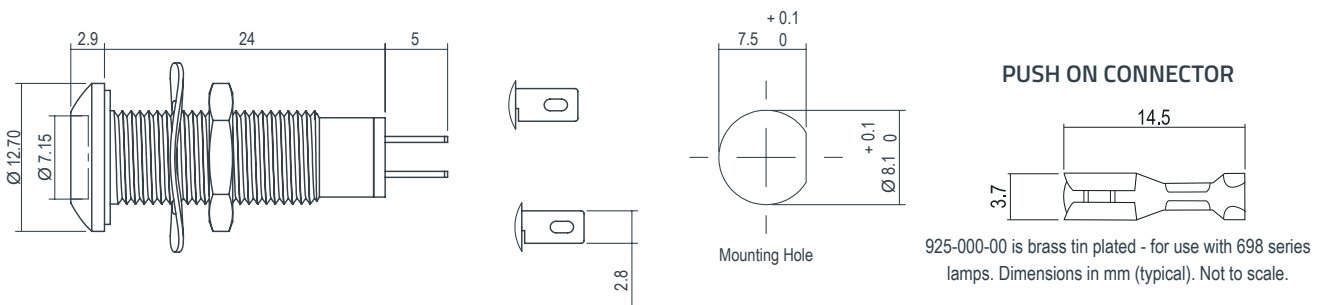

DE-RATING GRAPHS

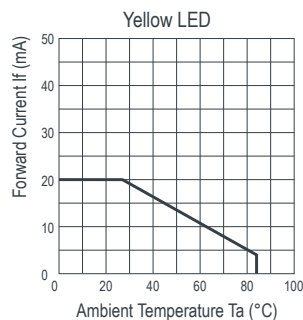
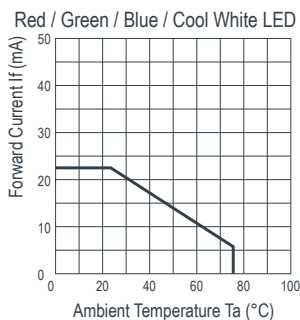

MATERIALS

Body	Aluminium Grade 6063 Black Anodised
Nut	Stainless Steel Grade 303
Panel Seal	Viton
Fresnel Lens	Polycarbonate
Encapsulation	Black Polyurethane
Lock Washer	Zinc Plated Steel
Termination	Silver Flash Coated Brass
Header	Nylon 66 A82

DESIGN CONSIDERATIONS

Electro-Static Discharge (ESD)

Build up of electro-static discharge occurs in many situations involving people moving and handling products. The range of possible situations is very diverse but voltage levels as high as several thousand volts can and do arise in many individual situations. When an operator charged up to these levels handles a static sensitive device, there is a very probable likelihood that the device will be irreversibly damaged. It is essential that precautions are taken at all stages during manufacture and assembly of these products. Although LEDs were never considered to be static sensitive devices, changes in manufacturing

technology and materials used to produce higher intensity products over a large range of the wavelength spectrum have changed this. MARL has an approved system of ESD control from goods in, through production and into final packing and dispatch. MARL recommend all users of LED based products follow the current BSI guidelines for protection of electronic devices from electrostatic phenomena.

Voltage, Current and Temperature

The forward voltage / current value of an LED is dependent upon the ambient temperature of the environment in which

it is operated. Therefore, care must be taken to operate the LED at the correct voltage / current values, depending upon the ambient temperature.

MARL should be contacted if the device is to be operated outside the temperature range specified. MARL accept no liability for any product that is operated outside the stated voltage or temperature range.

To order please contact us on +44 (0) 1229 582 430
F +44 (0) 1229 585 155 | E sales@marl.co.uk | www.leds.co.uk

in company/marl-international-limited

