

**PRODUCT:**

3032 SURFACE MOUNT LED

**FEATURES:**

3.0 mm × 3.2 mm × 0.62 mm surface-mount LED  
120° emission angle  
95 min Ra



**DESCRIPTION**

YUJILEDS® high CRI 3032 SMD provides a no-compromise high CRI, high efficacy solution in an industry standard PCT package. Providing 95 CRI (min) with the 2-in1 feature, this mid-power LED can be used in a variety of applications demanding high color quality and performance with the performance of tunable white.

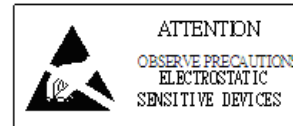

ELECTRICAL-OPTICAL CHARACTERISTICS (T <sub>A</sub> = 25 °C)							
PARAMETER	SYMBOL	VALUE			UNIT	TOLERANCE	CONDITION
		MIN.	TYP.	MAX.			
Forward voltage	V <sub>f</sub>	2.8	--	3.2	V	±0.05	I <sub>f</sub> = 150mA
Luminous flux	Φ <sub>2700K</sub>	40	--	45	lm	--	I <sub>f</sub> =150mA
	Φ <sub>3200K</sub>	45		50			
	Φ <sub>5600K</sub>	50		57			
	Φ <sub>6500K</sub>	50		57			
Correlated color temperature	CCT <sub>2700K</sub>	2550	2700	2850	K	--	I <sub>f</sub> = 150mA
	CCT <sub>3200K</sub>	3050	3200	3350			
	CCT <sub>5600K</sub>	5300	5600	5900			
	CCT <sub>6500K</sub>	6000	6500	7000			
Color rendering index	Ra*	95	--	--	--	±1	I <sub>f</sub> = 150mA
TCS R9 (CRI Red)	R9	--	90	--	--	--	I <sub>f</sub> = 150mA
Chromaticity coordinates	(X,Y)**	--	--	--	--	±0.0015**	--
Reverse current	I <sub>r</sub>	--	--	10	μA	±0.1	V <sub>r</sub> = 5V
Viewing angle	2θ1/2	--	120	--	Deg	±5	I <sub>f</sub> = 150mA

\*Typical Ra = 95 at 6500K.

\*\*Yuji Everfine standard equipment shall prevail.

ORDERING INFORMATION			
PART NUMBER	CCT	CHROMATICITY BINS	VOLTAGE RANGE
YJ-BC-3032-G03-2765	2700K ± 150K 6500K ± 500K	27M 65M	0.1 V
YJ-BC-3032-G03-3256	3200K ± 150K 5600K ± 300K	32M 56M	0.1 V
YJ-BC-3032-G03-XXXX	CUSTOM		

VOLTAGE BIN CODES				
Bin	V28	V29	V30	V31
V <sub>F</sub>	2.8-2.9	2.9-3.0	3.0-3.1	3.1-3.2

ABSOLUTE MAXIMUM RATING (T <sub>A</sub> = 25 °C)			
PARAMETER	SYMBOL	LIMIT	UNIT
Power Consumption	P <sub>D</sub>	1200	mW
DC Forward Current (pulsed)*	I <sub>Fp</sub>	300*	mA
DC Forward Current	I <sub>F</sub>	200	mA
Reverse Voltage	V <sub>R</sub>	5	V
Junction Temperature	T <sub>j</sub>	125	°C
Solder Point Temperature***	T <sub>s</sub>	105	°C
Operating Temperature	T <sub>opr</sub>	-40 ~ +85	°C
Storage Temperature	T <sub>stg</sub>	-30 ~ +85	°C
Soldering Temperature	T <sub>sol</sub>	260 ± 5	°C
Reflow Cycles Allowed	--	2	--

\* Pulse width ≤ 0.1ms, Duty ≤ 1/10.

\*\* Theoretical data.

\*\*\* See page 3 for solder point definition.

CHROMATICITY BINS & COORDINATES									
CCT	BIN	CIE 1931 COORDINATES							
		X0	Y0	X1	Y1	X2	Y2	X3	Y3
6500K	65M	0.3078	0.3245	0.3098	0.3131	0.3194	0.3230	0.3181	0.3349
5600K	56M	0.3247	0.3411	0.3253	0.3277	0.3358	0.3368	0.3360	0.3516
3200K	32M	0.4207	0.4047	0.4143	0.3887	0.4263	0.3931	0.4334	0.4091
2700K	27M	0.4562	0.4170	0.4477	0.4009	0.4631	0.4039	0.4727	0.4199

**CHROMATICITY BINS & COORDINATES**

**CIE 1931 COORDINATES**

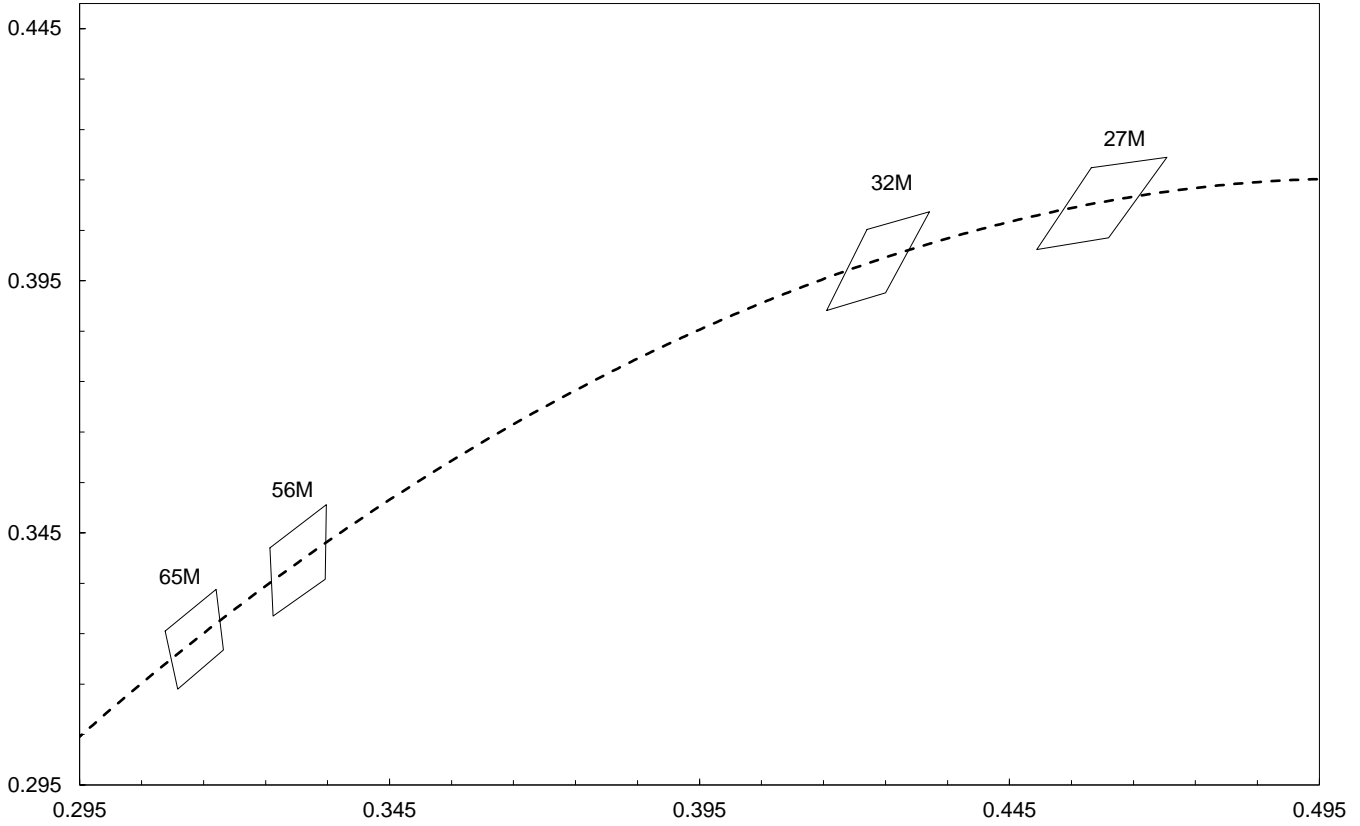

**PACKAGE LAYOUT**

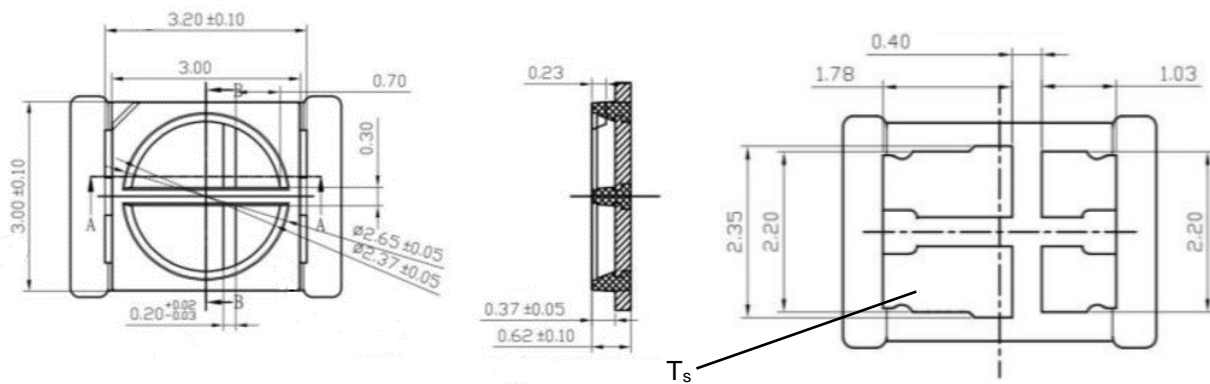

PACKAGE MATERIALS	
ITEM	DESCRIPTION
DIE MATERIAL	InGaN
LEAD FRAME MATERIAL	PCT
ENCAPSULANT RESIN MATERIAL	SILICONE + PHOSPHOR
ELECTRODES MATERIAL	SILVER-PLATED COPPER

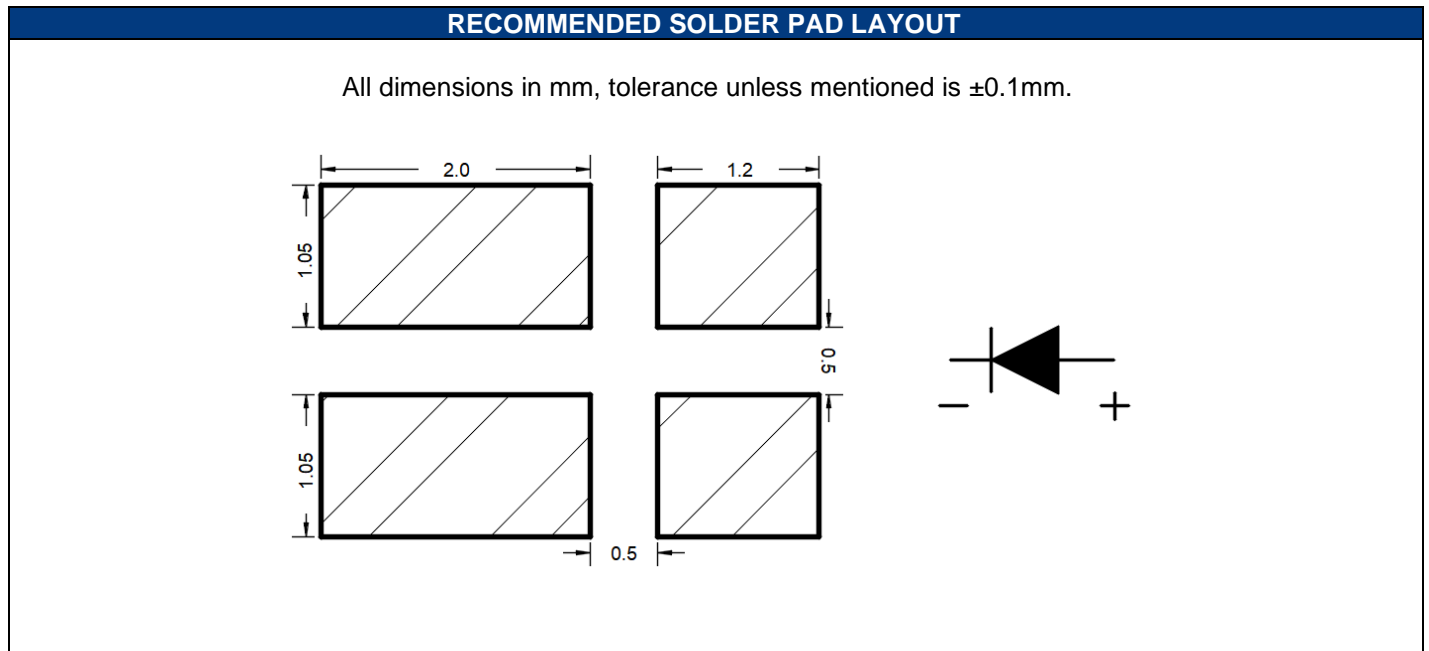

**CHARACTERISTIC CURVES**

ALL CHARACTERISTIC CURVES ARE FOR REFERENCE ONLY AND NOT GUARANTEED

**FORWARD CURRENT VS FORWARD VOLTAGE ( $T_A = 25^\circ\text{C}$ )**

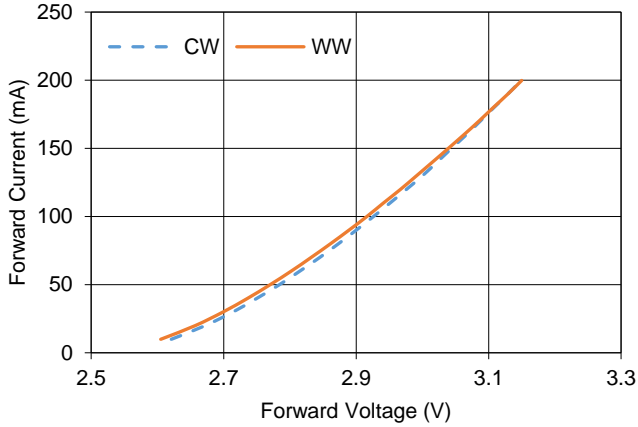

**FORWARD CURRENT VS RELATIVE LUMINOUS OUTPUT ( $T_A = 25^\circ\text{C}$ )**

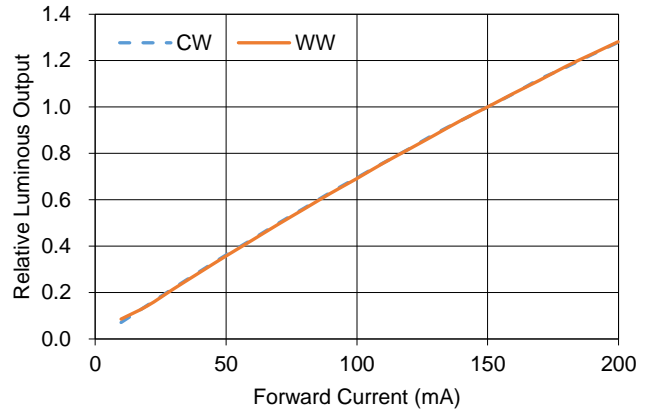

**SOLDER POINT TEMPERATURE VS FORWARD VOLTAGE ( $I_F = 150\text{ mA}$ )**

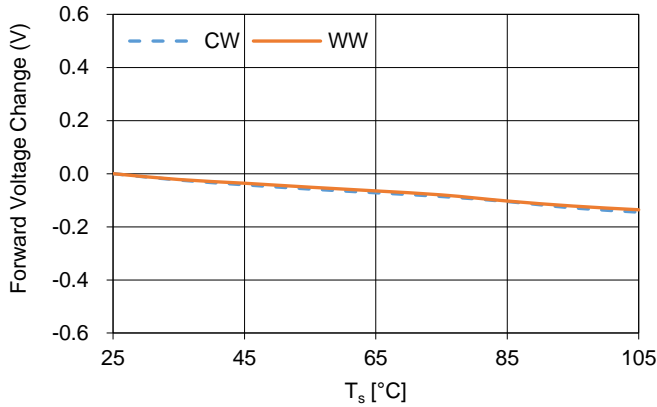

**SOLDER POINT TEMPERATURE VS RELATIVE LUMINOUS OUTPUT ( $I_F = 150\text{ mA}$ )**

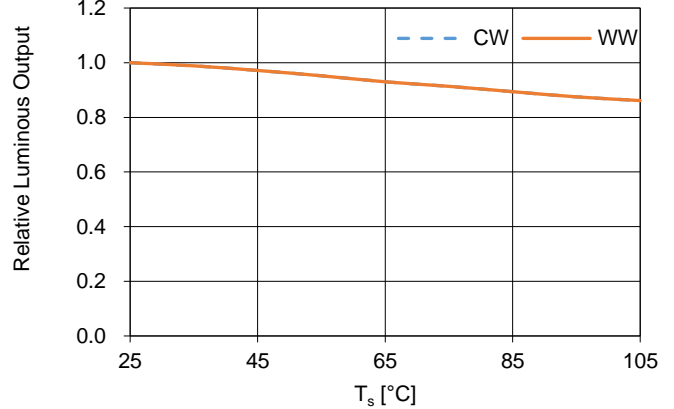

**FORWARD CURRENT VS CHROMATICITY SHIFT ( $T_A = 25^\circ\text{C}$ )**

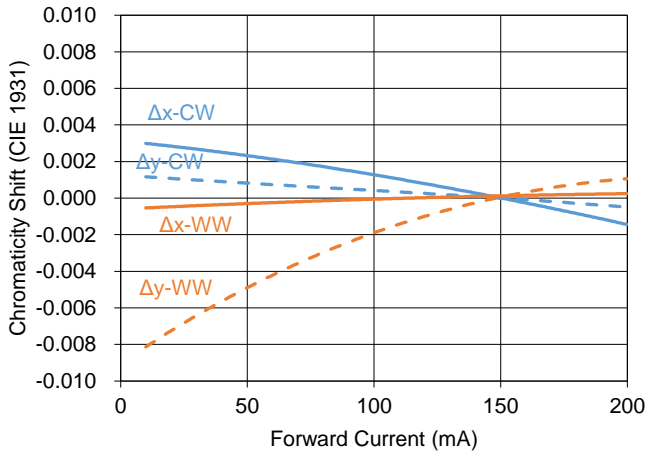

**FORWARD CURRENT VS CHROMATICITY SHIFT ( $I_F = 150\text{ mA}$ )**

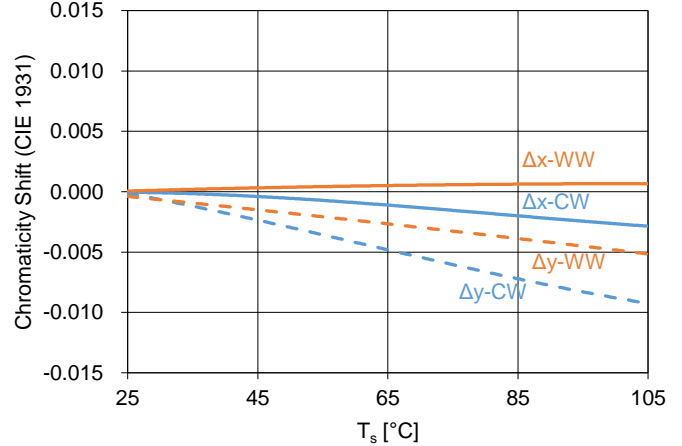

**TYPICAL SPECTRAL DISTRIBUTION GRAPHS**

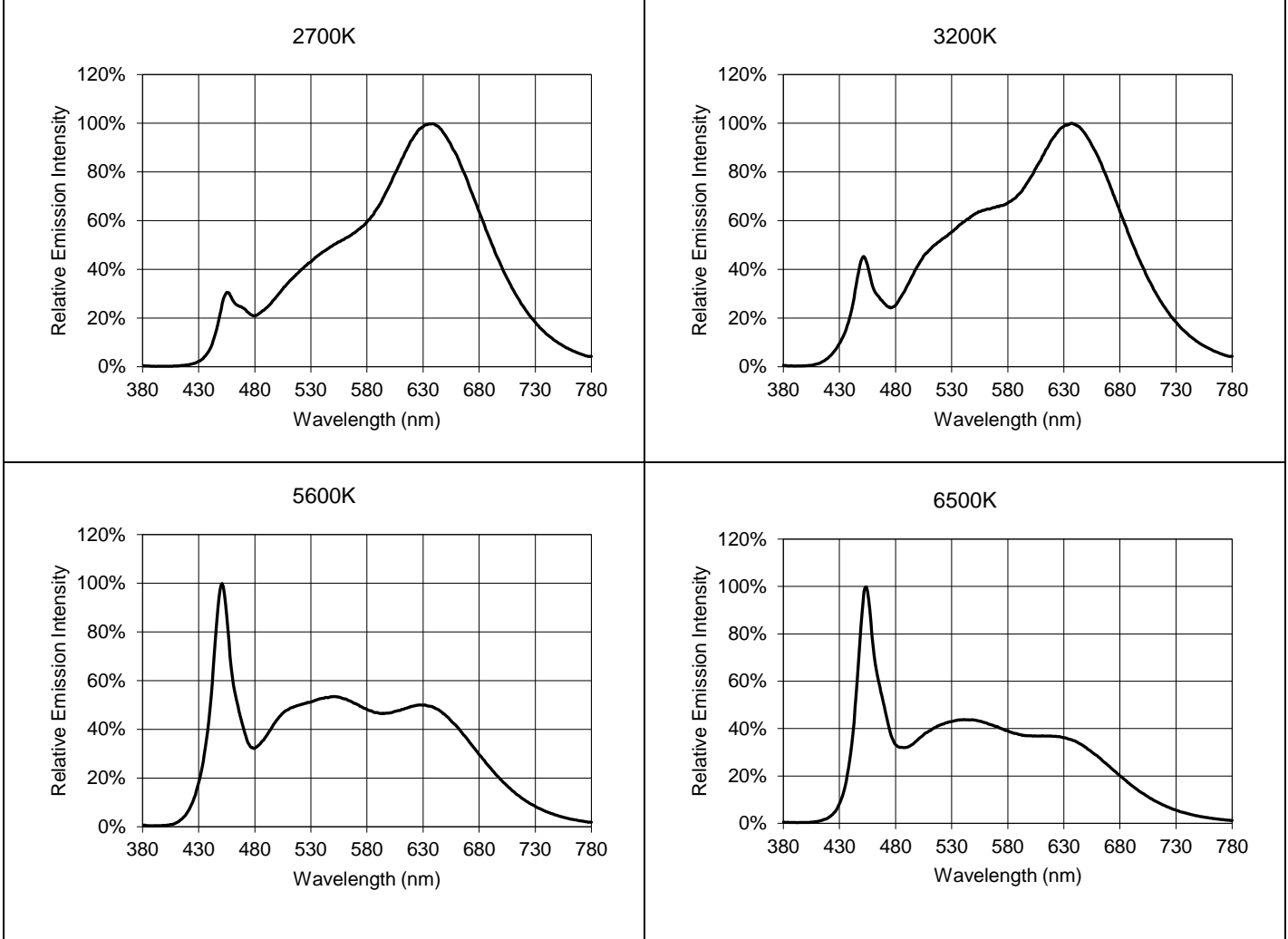

**REFLOW PROFILE**

**SOLDERING RAMP-UP TIME (Pb-FREE)**

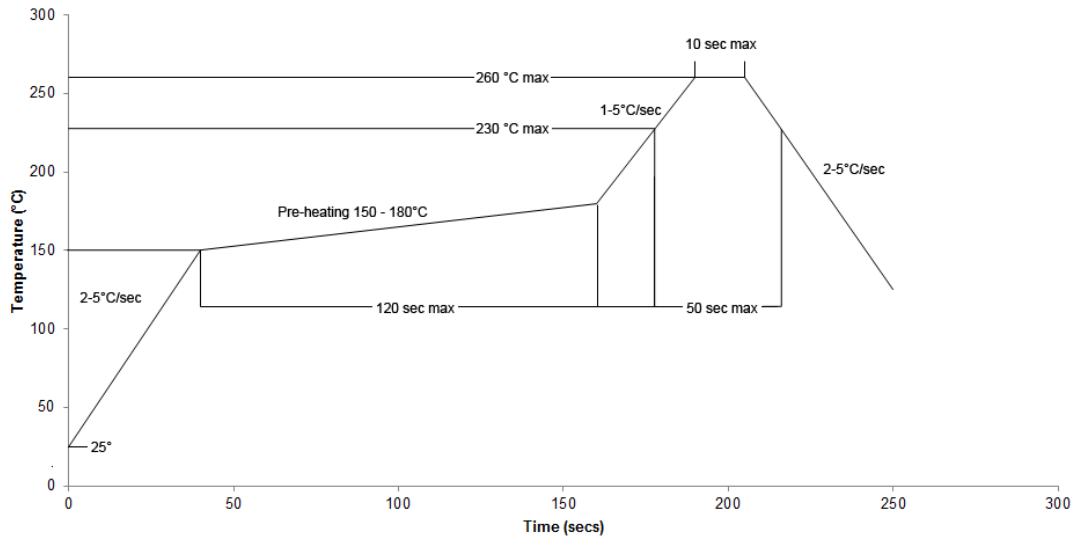

NOTE: Soldering paste with the melting point at 230°C is recommended

**INSTRUCTIONS FOR SMT**

**Problems caused by improper selection of collet**

Choosing the right collet is important in ensuring product quality after SMT. LEDs are different from other electronic components, as they are not only concerned with electrical output but also optical output. This characteristic makes LEDs more fragile in the process of SMT. If the collet's lowering height is not well set, it will bring damage to the gold wire at the time of collet's pick-and-place process which can cause the LED to not illuminate, flicker or contribute to other quality problems, some of which may not be immediately detectable.

**Collet selection**

During SMT, please choose the collet that has larger outer diameter than the lighting area of lens, in order to avoid damage the gold wire inside the LED. Different collets fit for different products, please refer to the following figures below.

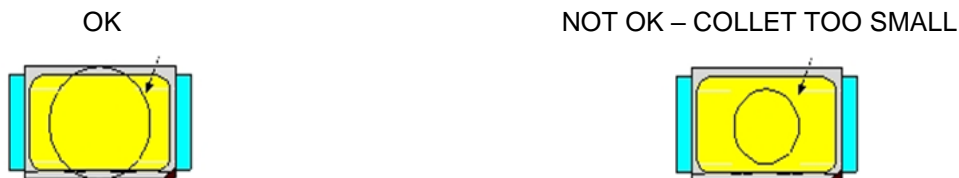

Setting the height of the collet is crucial in order to avoid damage to the top view SMD. If the collet setting is set to too low of an altitude, the collet will press down on the SMD, causing damage or breakage to the encapsulant and cause distortion or breakage of the gold wire.

**Other notes of caution:**

- No pressure should be exerted to the epoxy shell of the SMD under high temperature.
- Do not scratch or wipe the lens since the lens and gold wire inside are rather fragile and cross out easy to break.
- LED should be used as soon as possible when being taken out of the original package, and should be stored in anti-moisture and anti-ESD package.
- This usage and handling instructions are for reference only.

**TAPE SPECIFICATIONS**

TAPE DIMENSIONS (UNIT: MM)

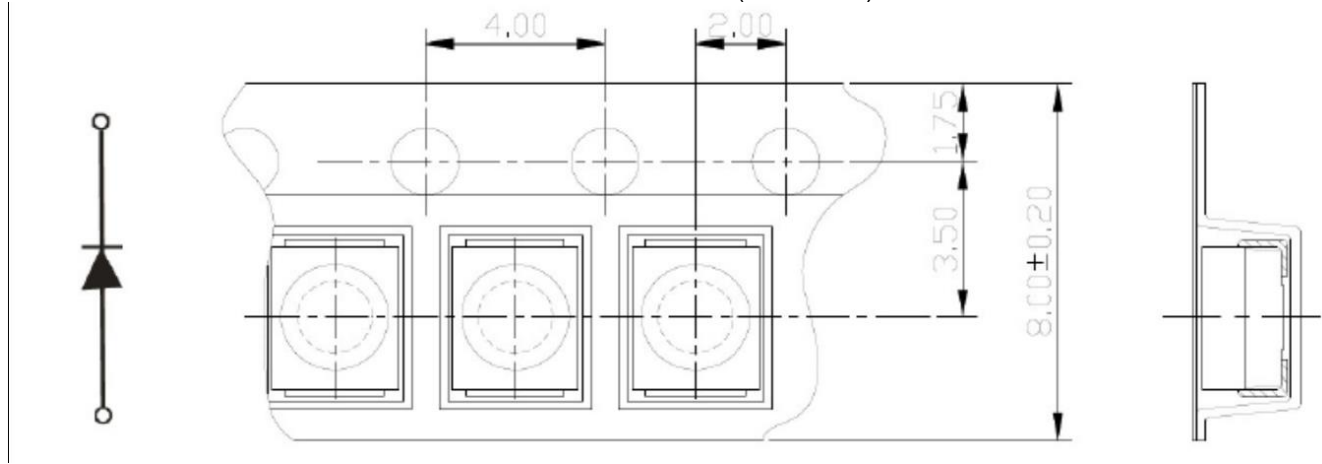

TAPE LAYOUT (NOT DRAWN TO SCALE)

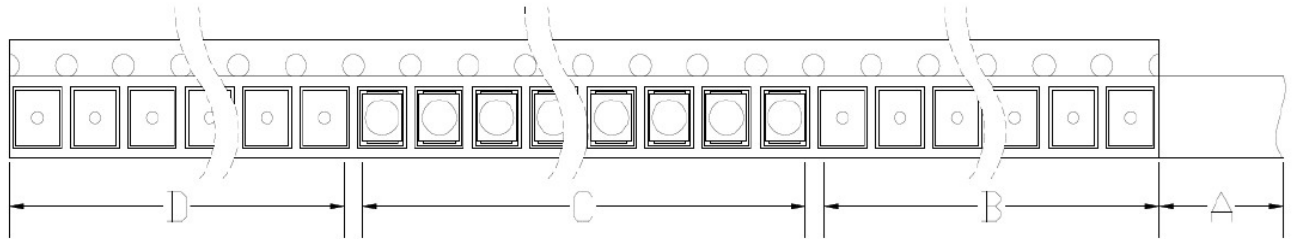

- A: COVER TAPE, 300 MM;
- B: EMPTY LEADER, 200 MM;
- C: LED, 4000 PCS;
- D: EMPTY TRAILER, 200 MM;

**REEL SPECIFICATIONS**

REEL DIMENSIONS TOP (UNIT: MM)

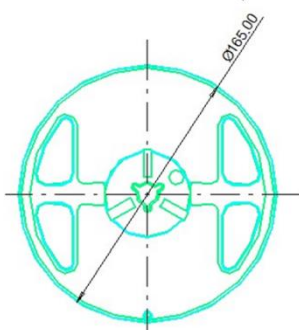

REEL DIMENSIONS BOTTOM (UNIT: MM)

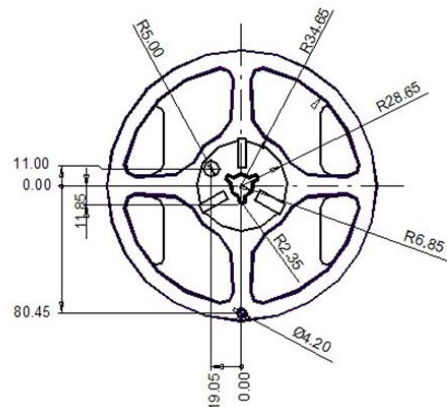



REEL DIMENSIONS SIDE (UNIT: MM)



FEEDING DIRECTION

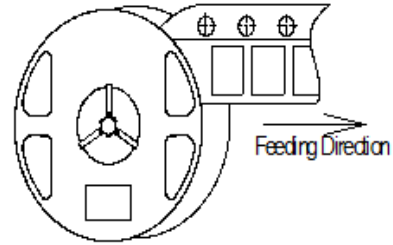

**LOT NUMBERING SCHEME**

Yuji LED uses two formats for lot numbering purposes:

1) YYYY-MM-XXX-Z

YYYY: 4-digit manufacturing year  
MM: 2-digit manufacturing month  
XXX: 3-digit inventory number (000 – 999)  
Z: internal alphanumeric code

2) YYYYMMXXX

YYYY: 4-digit manufacturing year  
MM: 2-digit manufacturing month  
XXX: 3-digit inventory number (000 – 999)

**SHIPPING INFORMATION**

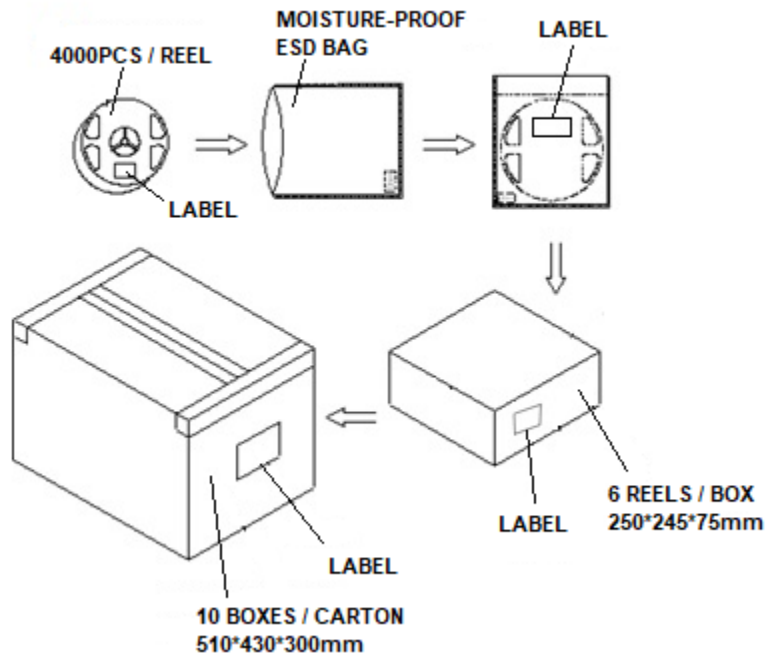

**NOTES:**

1. Reeled products (max 4,000 pcs / reel) are packed in a moisture-proof bag along with a moisture desiccant pack.
2. Each inner box contains up to 6 moisture-proof bag (total maximum number of SMDs is 24,000pcs). Box package size: 250 mm x 245 mm x 75 mm.
3. Each outer package contains 10 inner boxes. Box size: 510 mm x 430 mm x 300 mm.
4. Outer package is sealed with protective bubble wrap and foam. (Part numbers, lot numbers, quantity should appear on the label on the moisture-proof bag, part numbers).
5. This packaging merely intended as a reference for standard quantity orders only – please note that actual packaging can differ depending on the order circumstances.